

Thermakraft Wall Underlay

INSTALLATION PROCEDURES

1. Fix underlay with printed side facing the exterior
2. Fix to all exterior walls from below bearers to the top plate. Pull the underlay tight and fix securely to the frame with fasteners such as galvanized Little Grippers, 6mm-8mm staples or 20mm large head galvanized clouts at 300mm centres horizontally and vertically. Additional fasteners should be used around each opening to be cut out.
3. Thermakraft underlays are available in two widths 2740mm and 1370mm. The 2740mm is generally wide enough to come from below the bottom plate to the top plate.
4. When fixing underlay to steel framing the same procedures applies, use adhesive spray, tape or flat head screws to fasten to the framing or thermal break, the exterior cladding fastenings will act as the permanent fixings.
5. Cover all windows and door openings with underlay.
6. It is recommended that the wall underlay is not cut and prepared for window installation until the arrival of the windows.
7. A minimum of 150mm lap is required at joins, all vertical laps must be made over studs. Horizontal laps to be laid ship lap style allowing water to be shed to the outer face of the membrane
8. When windows and doors are ready for installation, the underlay covering the openings should be cut at 45 degrees and folded into the opening and securely fastened. Thermakraft Aluband Window Sealing System is recommended as the window flashing system.
9. NB. In accordance with NZBC Acceptable Solution E2/AS1 Paragraph 9.1.8.5, wall wrap must be prevented from bulging into the drained cavity. Where stud spacing is greater than 450mm Thermakraft stud strap run horizontal at 300 centres is an acceptable means of prevention.
10. Once installed Thermakraft underlays may be left exposed to the weather (refer table below for Maximum time). Thermakraft underlays will provide temporary weather protection during construction allowing work to continue. Internal linings and insulation must not be installed until the exterior cladding is completed
11. Fastenings behind Brick Veneer Cladding must have an equivalent service life to that of Brick Veneer (50 years). Refer to NZBC 3604 Table 4.1, and 4.3.
12. Make good any forced tears with Thermakraft White GP tape. Any large areas which require repair may be covered with a second layer of underlay, a lap of 150mm is required.

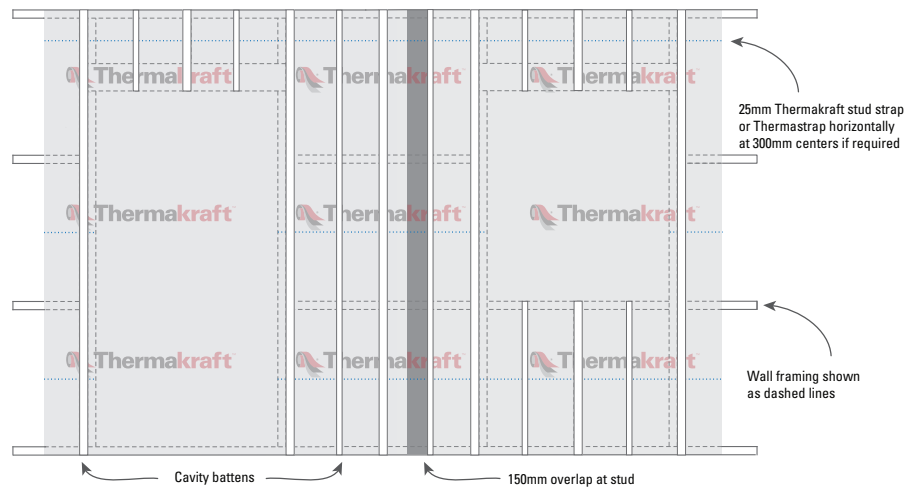

EXPOSURE TIME

Product	Watergate Plus 295	SteelWrap 290	Thermakraft 220	Thermakraft 213/215	Covertex 403 Plus	Covertex 407/405
Max Days exposure	60	42	42	Wall application 28 Roof application 7	Wall Application: 42 Roof application: 7	Wall Application: 14 Roof application: 7

HANDLING AND STORAGE

- » Due to the width of the sheets care should be taken when installing in windy conditions due to the large sail effect.
- » Store in clean dry conditions, not in direct sunlight.
- » Ensure rolls are not damaged.
- » There are no environmental issues associated with the use of Thermakraft underlays.

INSTALLATION DETAILS WINDOW FLASHING TAPE

1. Cut the wall underlay/air barrier at a 45° angle away from each corner. Fold flaps tightly into the window or door opening and fix with staples on the back faces of the framing.

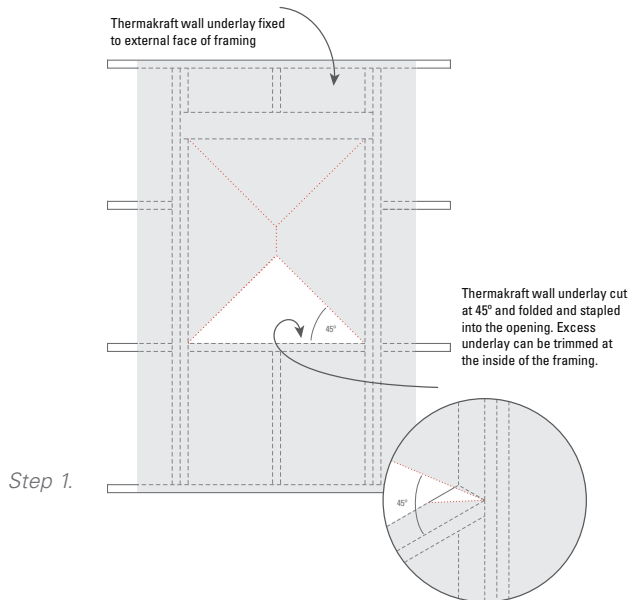

3. Cut a length of Thermakraft window flashing tape the length of the sill plus 400mm.
4. The tape is installed flush with the interior face of the opening and applied to the full length of the opening and 200mm up the jamb.
5. Using the Thermakraft Tool, firmly press the tape onto the wall underlay to ensure good adhesion and ensure the tape is fitted tightly into the jamb to sill corners.
6. At the sill/jamb corners cut the tape from the external edge of the frame (200mm across lintel x 200mm down jamb) and press tape firmly for good adhesion.
7. Proceed to fit the Window Flashing Tape to the top corners of the frame (200mm across lintel x 200mm down jamb).
8. For window or door lintel to jamb junction, apply a butterfly using the 75mm wide x 100mm long Aluband. Fix at a 45° angle to the jamb with an overlap at the corner of 3mm.

2. Fix the Thermakraft Corner Moulded Piece to the bottom corners by way of staples or clouts to the two jambs. Always ensure that Aluband/Bulldog is applied to surfaces that are clean and free of dust, contaminants, solvents, oils or waxes. Note the following: 150mm wide tape is used for 100mm wide window or door framing, and the 200mm wide tape is used for 140mm to 150mm wide framing. (With steel framed houses use Double Sided Tape to attach the Thermakraft Aluband Corner Moulded Piece to metal framing).

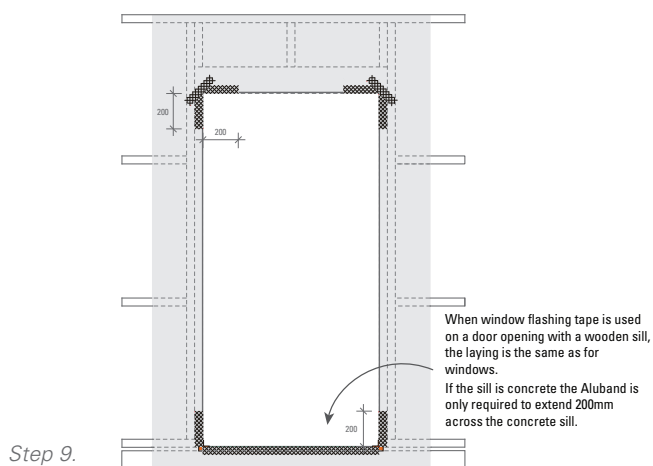
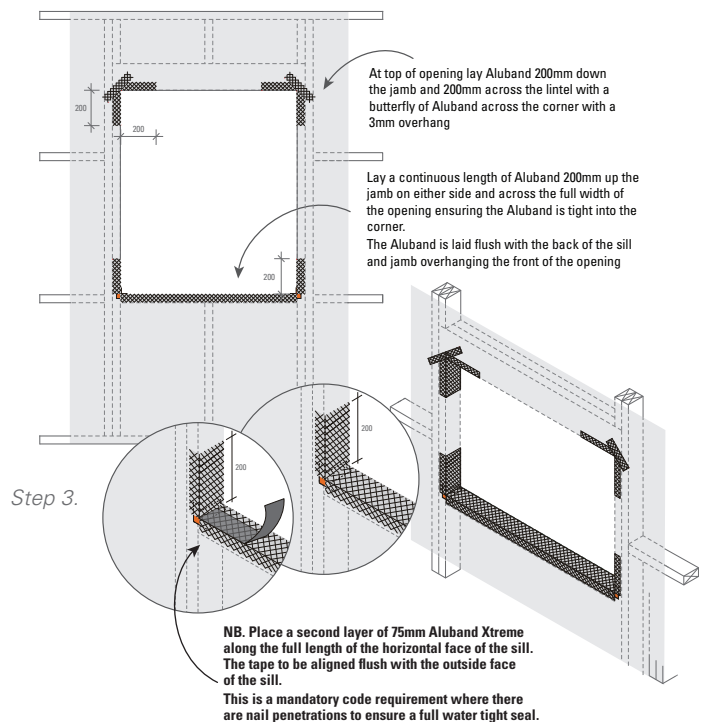
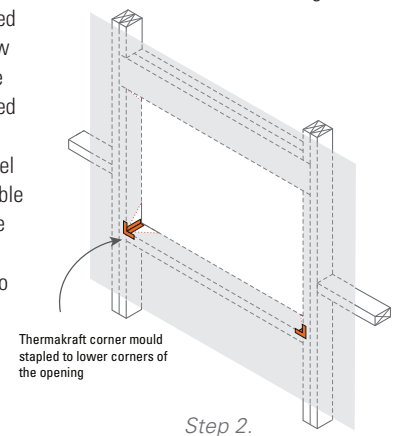

9. Door frames are to be treated similarly to window openings. The sill may be either a timber or a concrete floor.
Window and door frames
 - a) Staple orange corner piece to the bottom corner sill. Place tape 200mm up the jambs and across the full width of the sill opening. Align tape with the back of the frame opening.
 - b) At the top corner place tape 200mm down the jamb and 200mm across the lintel. Place a strip of 75mm tape across the top corner.
10. Meter boxes with built-in flanges to be taped with Window Flashing Tape along each flange to the building underlay.
11. Window Flashing Tape is used to seal the up stand of the window head flashing to the building underlay. (Refer to the cladding manufacturer's details).